



SecurityCloak: Protection against cache timing and speculative memory access attacks

Fernando Mosquera ^{a,*}, Ashen Ekanayake ^b, William Hua ^a, Krishna Kavi ^a, Gayatri Mehta ^a, Lizy John ^b

^a University of North Texas, United States of America

^b University of Texas at Austin, United States of America

ARTICLE INFO

Keywords:

Side-channel attacks
Speculative execution
Victim cache
Spectre
Prime & probe
Evict & time
Flush & reload
Guard cache

ABSTRACT

Microarchitectural innovations such as deep cache hierarchies, out-of-order execution, branch prediction and speculative execution in modern processors have made possible to meet ever-increasing demands for performance. However, these innovations have inadvertently introduced vulnerabilities that are exploited by cache-side channel attacks such as Flush & Reload, Prime & Probe, Evict & Time, and attacks such as Spectre and Meltdown that exploit speculative executions. These attacks can potentially leak information which should be secured.

Mitigating the attacks while preserving the performance of out-of-order execution has been a challenge. Previous hardware mitigation techniques against cache timing or side-channel attacks include complex cache indexing mechanisms, encrypting addresses, partitioning cache memories, assigning specific ways of a set for each process, or obfuscating cache accesses by using ghost threads. Previous techniques for preventing or at least mitigating attacks based on speculative executions include hiding speculative data accesses using separate buffers or caches, or undoing the effects of speculation throughout program execution. Most techniques address either attacks that exploit speculation such as Spectre or cache side-channel attacks but not both. In many cases, changes to the microarchitecture with additional hardware are needed to implement the security protection. In some cases the mitigations cause performance penalties. In contrast we present very simple designs aimed at preventing both timing based cache side-channel attacks and Spectre style attacks based on speculative executions. Our approach combines obfuscation of cache timing making it more difficult for side-channel attacks to succeed and delaying speculative data accesses that miss in cache until the speculation is resolved. We will show that these approaches prevent both timing attacks such as Flush & Reload, Prime & Probe, Evict & Time as well as speculative attacks such as Spectre. Our technique requires very minimal changes to hardware.

1. Introduction

Over the past few decades, computer systems have introduced many major microarchitectural innovations including deep cache hierarchies, out-of-order instruction execution, branch prediction and speculative execution, and issuing multiple instructions per cycle, just to name a few. These innovations were motivated by the need for higher performance at lower energy consumption. However, these innovations have inadvertently introduced vulnerabilities that can potentially leak information that should be secured. The information may be leaked either through a side-channel or direct (modification to application code) attacks.

Among the earliest attacks discovered is a side-channel to information stored in cache memories by observing memory access times,

which in turn reveal if an access (to an address) is a hit or a miss in cache. An attacker can use this side-channel to deduce the memory addresses accessed by a victim and extract additional information such as keys used by encryption in AES [1,2]. Some common side-channel attacks include Evict & Time [3], Prime & Probe [3,4] and Flush & Reload [5].

Yet another modern hardware side-channel attack is made possible by the use of out-of-order and speculative execution of instructions [6]. In such systems, processors rely on predictions as to which execution path to proceed along, even before completing the branch instruction that determines the correct path. In most cases, the predictions are very accurate. When the prediction is wrong, the processor squashes (or undoes) the computations along the mispredicted path. This is achieved

* Corresponding author.

E-mail addresses: FernandoMosquera@my.unt.edu (F. Mosquera), ljohn@ece.utexas.edu (L. John).

<https://doi.org/10.1016/j.sysarc.2024.103107>

Received 5 July 2023; Received in revised form 21 February 2024; Accepted 6 March 2024

Available online 9 March 2024

1383-7621/© 2024 Elsevier B.V. All rights reserved.

by the use of reorder buffers (ROB). However, when a mispredicted path contains memory accesses (particularly read access), and if the accessed data is not available in cache memories (i.e., read miss), the processing system will bring the data into cache memories. Even when the misprediction is detected and all instructions along the mispredicted path are squashed, the data brought into the cache is not invalidated. At a later time, the attacker can rely on a side-channel to access this data in the cache, which may contain secret information.

Computer architects have been investigating techniques to either prevent or at least mitigate (making it harder for an attacker to successfully launch attacks) these attacks. The solutions can be implemented in software or hardware. For example, ASLR [7] randomizes kernel address space to make it more difficult for the attacker to deduce secret information based on addresses accessed by a victim. This requires no hardware changes but works for Meltdown [8] but does not prevent many Spectre variants [9]. Likewise, preventing “deduplication” [10] eliminates some attacks since shared libraries will have multiple copies but can lead to significant performance penalties.

Hardware techniques to mitigate timing based cache side-channel attacks include partitioning caches so that only one process can access its partition (and no other process can evict data contained in those partitions), changing cache indexing mechanisms or encrypting how an address is mapped to a cache index so that cache misses to an entry cannot easily be translated into addresses, among others [2,4,11–15]. Mitigation of speculative attacks can be categorized into three broad groups: (i) prevent speculation altogether or at least prevent speculative execution of certain instructions, (ii) make speculative execution “invisible” either by buffering all memory accesses performed until speculation is resolved or delaying memory accesses (at least accesses that cause cache misses) until speculation is resolved and (iii) “clean-up” all affects of speculative execution, including evicting any speculatively fetched data from caches.

It should be noted that most published mitigation or prevention techniques address either speculation based attacks or timing based attacks but not both. In this work, we present very simple hardware mitigation techniques that together can address both timing based cache-side channel attacks and illegal or unauthorized memory accesses during speculative execution. We explore various techniques to obfuscate micro-architectural information making it more difficult for attackers.

The main contributions of our work (SecurityCloak) are:

- **Delaying speculative load misses:** Many of the attacks rely on fetching data into the cache during speculation, including the data along misspeculated paths or along unauthorized access paths. Existing techniques allow such accesses but either hide the fetched data using additional caches or buffers [16], or evict such data from cache hierarchies when the misprediction is detected [17]. In our approach, we permit speculative executions and memory accesses that hit in (L1-D) cache but delay memory accesses that miss in the cache until the speculation is resolved. We refer to this technique as *SafeLoadOnMiss*. A very similar approach was previously proposed in [18]. We make the following modifications to the previous approach:
 - we hold the delayed cache misses in a separate *Safe Queue* and use instruction sequence numbers¹ to order the misses when the speculation is resolved instead of dropping the load misses and allowing the LSQ to retry later as done in [18] - this reduces performance penalties;
 - we use random replacement in primary cache instead of LRU replacement, potentially mitigating some speculative interference attacks [19], as stated in [20].

Our experiments show that this will result in very minimal performance loss and requires minimal hardware: only 5.4% geometric mean performance loss for SPEC2017 benchmarks, and only 160B of additional storage for *safe queue*.

- **Obfuscating cache timing with false hits:** We use a small fully associative Cache (labeled Guard Cache) which is used both as a Victim cache and a Miss cache [21] to create false hits. Any data item evicted from the primary cache is saved in this Guard Cache. If the evicted item (or victim) is accessed, it can be retrieved from Guard Cache, making the access appear as if it was a hit in the primary cache. To further obfuscate timing, we also rely on *random replacement policy* when entries in Guard Cache need to be replaced. Additional obfuscations can include randomly not placing “victims” in Guard Cache, thus causing false hits more randomly. While larger Guard Caches can provide more protection since victims can be held for longer periods of time but can lead to higher silicon area and power consumption, we found that even a small Victim Cache (1 KiB to 4 KiB), may be sufficient to prevent several types of attacks, particularly those that rely on Flush & Reload side-channels.
- **Obfuscating cache timing with false misses:** We randomly evict cache lines to cause false misses. On every cache hit, we choose a random cache line for eviction and evict those items based on how often a cache line should be evicted (eviction frequency). While such evictions can cause performance penalties, we have shown that even 10% eviction frequencies can prevent attacks that are based on Prime & Probe side-channels.
- **Safe-mode execution:** The microarchitecture enters a preventive state to mitigate known hardware security attacks such as Spectre and Meltdown as well as a variety of cache side-channel attacks. The *safe* mode can be turned-on by the user to assure secure execution of critical sections of their programs. Or the system can be endowed with the capability to detect the presence of an attack and turn-on the *safe* mode. In this way, the system will experience performance impacts only during the *safe* mode execution. It may also be possible to randomly switch between *safe* and *unsafe* modes of execution to make it more difficult for an attack to succeed. This may also make it more difficult for speculation-interference attack [19] to succeed.

The rest of the paper is organized as follows. Section 2 describes the background and motivation for our work. Section 3 describes our SecurityCloak framework design and implementation. Section 4 provides performance results as well as the experimental framework used for the evaluation. Section 5 includes relevant research that is related to our work and Section 6 summarizes our conclusions about SecurityCloak framework.

2. Background and motivation

In pursuit of meeting ever-increasing demands for processor performance, computer systems implemented many major microarchitectural innovations including deep cache hierarchies, out-of-order instruction execution, branch prediction, and speculative executions, issuing multiple instructions per cycle, just to name a few. However, these innovations have inadvertently introduced vulnerabilities that can potentially be exploited to leak information that should be secured. The information may be leaked either through a side-channel or direct (modification to application code) attacks. The two types of attacks that have been widely discussed are cache side-channel attacks (for example, [3–5,22,23]) and speculative attacks (like Spectre [9,24] and Meltdown [8]). Computer architects have been investigating techniques to either prevent or at least mitigate (making it harder for an attacker to successfully launch attacks) these attacks. The solutions can be implemented in software or hardware.

Among the hardware techniques against cache side-channel attacks include (i) partitioning caches so that only one process can access

¹ The instruction sequence numbers in Gem5 can be viewed as time stamps.

Table 1

Average performance loss for SPEC 2006 benchmarks for different mitigation techniques.

Mitigation technique	Average performance loss (%)	Hardware complexity
InvisiSpec-Spectre [16]	5.0	Medium
InvisiSpec-Futuristic [16]	17.0	Medium
CleanupSpec [17]	5.1	Medium
Delay on Miss [18]	11.7	Low
GhostMinion [20]	2.5	Medium

Our SafeLoadOnMiss technique is similar to [18]. However, our implementation results in smaller performance losses. Also, we collected data for SPEC 2017 benchmarks and not SPEC 2006.

its partition (and no other process can evict data contained in those partitions); (ii) changing cache indexing mechanisms or (iii) encrypting how an address is mapped to a cache index so that cache misses to an entry cannot easily be translated into an address [2,4,11–15].

Spectre-style attacks that rely on speculative execution can be mitigated by:

- Disabling speculation. This can lead to significant performance losses (as much as 89.6%, see Table 5).
- Making invisible the effects of speculatively executed instructions. This can be achieved by using additional hardware mechanisms such as buffers or caches [16,20], and committing or discarding these buffered results on branch resolution.
- Undoing all effects of speculatively executed instructions. This requires not only squashing speculatively executed instructions but also invalidating any data that was speculatively brought into cache hierarchy [17].
- Delaying load misses caused by speculatively executed instructions (we call this SafeLoadOnMiss). In our approach (which is somewhat similar to [18]) we permit speculative execution of instructions that either do not access memory, or memory accesses that hit in (L1-D) cache, but do not permit (or delay) memory accesses that miss in cache.² As we will show in later sections, our approach incurs minimal overheads in terms of hardware extensions needed and also causes very small performance degradation.

The performance losses caused by these different techniques are shown in Table 1. As can be expected, different mitigation techniques cause different amounts of performance loss and the hardware complexity also varies with these solutions.³ The performance loss depends on application behavior. For example, an application that has higher cache miss rates will likely see higher performance losses when “Delay Load Misses” [18] technique is used. Likewise, “Undo” [17] technique needs to invalidate more cached entries. Obviously, fewer conditional branches result in fewer speculatively executed instructions and smaller amounts of performance losses even if we disable speculation completely. Although not shown in Table 1, we observe that memory intensive benchmarks and benchmarks with very high MPKI rates (e.g., mcf) cause significantly higher than average performance losses in all the known mitigation techniques.

In a recent paper [25], the authors describe a graphical model to understand speculation-based attacks such as Spectre and its variations. Fig. 1 shows a slightly modified version of the attack graph. The key observation for our purpose is that there is a delay from the time

² We understand this technique may not prevent Speculative Interference attacks [19]. However, as indicated in [20], such attacks can be made more difficult by relying on random replacement policy. We will discuss this in a later section.

³ The performance numbers and hardware complexity is based on the data from the cited publications.

a conditional branch (or authorization) is executed, initiating speculative execution until when the branch is resolved (or authorization resolved). The speculatively executed instructions during this interval either commit or are squashed based on the resolution. One observation that can be drawn from the model presented in [25] is that the longer the delay in resolving a branch decision (or resolving authorization), the more likely an attack will be successful. In one of the Spectre-like attacks (see Listing I) that rely on Flush & Reload technique, the array bounds variable (Asize) is flushed from cache. This causes delays in resolving array bounds check (line 5) since the bounds variable needs to be fetched into L1-D cache. The speculative load instructions (lines 6 and 7) along the mispredicted (or unauthorized) path will more likely complete fetching the data (secret) into cache, which will be accessed by attacker at a later time. This delay will also correlate to the performance impacts of the various solutions outlined above. For example, the “Undo” technique may need to invalidate more cached data if the delay is longer; or “Delay Load Misses” [18] or our variation SafeLoadOnMiss may delay several load accesses resulting in higher performance penalties.

```

1  Asize = 16
2  A[16] = {0, 0, ..., 0}
3  B[256 * 512]
4  .....
5  if (x < Asize) { //mispredict
6      secret = A[x]
7      temp = B[secret * 512]
8  }
```

Listing I: A Proof of Concept Spectre Attack [17]

If it is possible to *turn-on* the mitigation only when needed (either when an attack is detected, or while executing certain critical code segments), even the simplest technique (such as preventing speculative execution completely, or preventing speculative memory accesses) will be acceptable since performance penalties occur only when the mitigation is on.

Although we focus on side-channel and speculation-based attacks, the concept of *on demand* protection is applicable to any known or potentially new attacks. And the on demand security protection can be based on attack detection techniques proposed by researchers or new techniques that may be proposed against new attacks. The techniques should be amenable to turning-on and turning-off on demand. Some techniques may require extensive overheads when the system transitions between *safe* state and *unsafe* state, including activating and deactivating certain structures or copying data between hidden buffers (or GhostMinion [20]) and primary cache memories.

To be able to *turn-on* protection automatically, it is necessary to investigate how an attack can be detected. Side-channel attacks rely on cache accesses, thus most existing methods for detecting side-channel attacks rely on the use of hardware performance counters to extract data of the cache utilization and use machine learning techniques to detect attack patterns [3,4,26–28].

To be practical, a detection technique should provide real-time detection capabilities, result in low levels of false positive and false negative alarms, and incur only small amounts of hardware overhead to monitor the system. With this in mind, our detection of Spectre-like attacks and other side-channel attacks on cache memories is based on monitoring cache flush operations. However, other known monitoring and detection techniques can also be used as long as they satisfy the requirements listed above.

To summarize, we feel that *On Demand* security can provide a trade-off between performance and security, by using protection or mitigation against attacks only when an attack is detected (or suspected), or to protect critical sections of applications. One may also *Turn On* and *Turn off* security protection randomly to make attacks significantly more difficult to succeed.

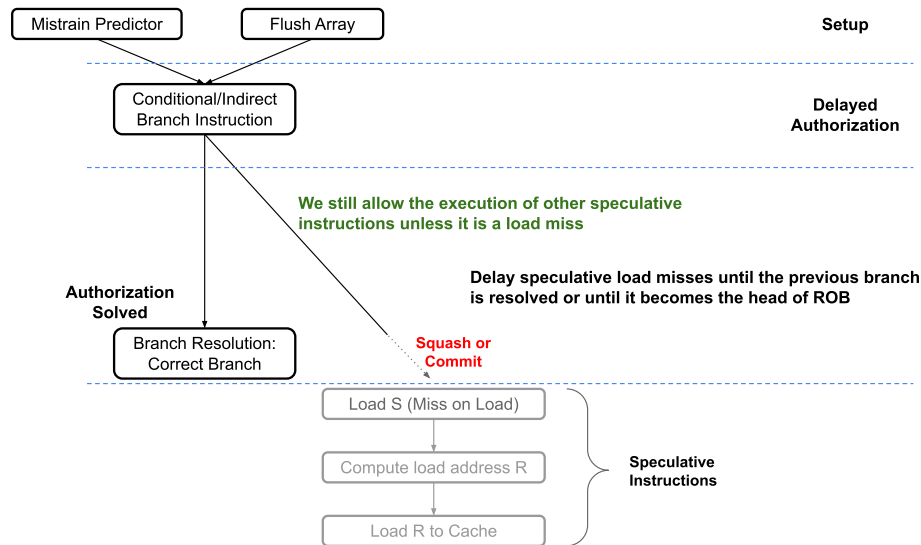

Fig. 1. Attack graph of the SafeLoadOnMiss scheme.

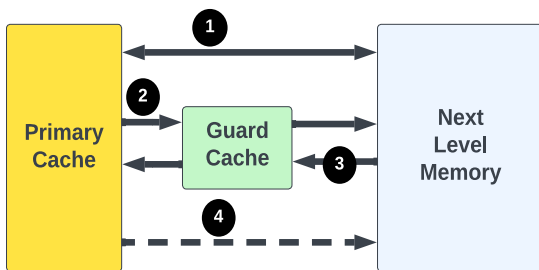

Fig. 2. Guard cache to create false hits. A similar structure can be used at L2.

3. SecurityCloak framework

Our goal is to facilitate *On Demand* protection against hardware security attacks. In our approach, we explore supporting the ability to protect critical code sections by entering safe modes. For example, this can be achieved using `Enter_Safe_Mode()` and `Exit_Safe_Mode()` system calls as shown in Listing II. Only the process that activated the safe mode can deactivate the protection.

```

1  Enter_Safe_Mode();
   .....
3  Critical_code
   .....
5  Exit_Safe_Mode();
    
```

Listing II: On Demand Protection

While any security mitigation technique can be relied upon for protection, the techniques should be easy to be *turned on* and *turned off*, incurring minimal overheads in switching between safe and unsafe modes. It may also be possible to include multiple mitigation techniques for different types of attacks and users can select a mitigation technique based on the level of security desired, for example, as an argument to `Enter_Safe_Mode()` call.

It may be possible to automatically enable safe mode when an attack is detected (or suspected) - the mitigation selected can be based on the type of attack detected. SecurityCloak framework can use any known detection approaches for some known detection techniques. It is also necessary to determine when it is okay to exit the safe mode. More advanced invocation of safe modes in the presence of persistent or

repeated attacks can include techniques similar to “*exponential back-off*” whereby the amount of time spent in safe mode increases every time the safe mode is invoked. With these goals, we will describe our SecurityCloak design using Gem5 [29]. While in *Safe Mode* we can use either our Guard Cache to mitigate cache timing attacks or use *Safe Queue* to delay load misses during speculative execution, or both. To make Speculative Interference attacks [19] more difficult, we use random replacement policy in our caches while in *Safe Mode*.

3.1. Creating false hits and false misses

Cache side-channel attacks rely on measuring memory access times to determine if an access to a specific cache line (or set) is a hit or a miss: a miss causes longer access times. This observation can be used by an attacker to obtain information regarding which memory addresses a victim accessed, and possibly retrieve data from those addresses.

Victim Caches are generally very small and fully associative caches and were originally used to improve performance by eliminating cache *thrashing* in direct mapped caches [21]. In a more recent work [30], victim caches were used to house data evicted by speculative load accesses (for example, ReViCe [30]). We feel this requires complex bookkeeping since one needs to distinguish between speculative and non-speculative load accesses, as well as remove misspeculated data from victim cache. We use Guard Caches similar to Victim Caches to create false hits — any data item evicted from the primary cache is saved in the Guard Cache. If the evicted item is accessed, it can be retrieved from the Guard Cache, making the access appear as if it was a hit in the primary cache, since the access times to a Guard Cache and primary cache are comparable. We also rely on *random replacement policy* when entries in the Guard Cache need to be replaced, to further obfuscate information leak. Also, not every data evicted from primary cache is placed in the Guard Cache but treated as a normal cache miss.

We will also use the Guard Cache as a *Miss Cache* [21]— the missing data is brought into the Guard Cache, unlike in the case of a victim cache where the missing data is brought into the primary cache and the evicted data is stored in the Guard Cache. Such data items are likely to be short lived in Guard Cache unlike when the data is brought to primary cache since Guard Cache is very small compared to primary caches. This can add to additional obfuscation to cache timing. These different uses of the Guard Cache make it difficult for an attacker to discover the presence of a Guard Cache, its size or when it is used or not used. We saw negligible performance gains or losses with Guard Caches: larger Guard Caches can provide more protection since victims

Baseline	10% False Misses	False Misses + False Hits
237: Load_Miss Addr: 0x50600	281: Load_Miss Addr: 0x50600	289: Load_Miss Addr: 0x50600
238: Load_Miss Addr: 0x50640	282: Load_Miss Addr: 0x50640	290: Load_Miss Addr: 0x50640
239: Load_Miss Addr: 0x50680	283: Load_Miss Addr: 0x50680	291: Load_Miss Addr: 0x50680
240: Load_Miss Addr: 0x506c0	284: Load_Miss Addr: 0x506c0	292: Load_Miss Addr: 0x506c0
241: Load_Miss Addr: 0x50700	285: Load_Miss Addr: 0x50700	293: Load_Miss Addr: 0x50700
242: Load_Miss Addr: 0x50740	286: Load_Miss Addr: 0x50740	294: Load_Miss Addr: 0x50740
243: Load_Miss Addr: 0x50780	287: Load_Miss Addr: 0x50780	295: Load_Miss Addr: 0x50780
	288: Load_Miss Addr: 0x4ef80	296: Load_Miss Addr: 0x4ed80
	289: Store_Miss Addr: 0x503c0	
	290: Load_Miss Addr: 0x4e040	
	291: Load_Miss Addr: 0x4f500	
244: Load_Miss Addr: 0x4ed80	292: Load_Miss Addr: 0x4ed80	297: Load_Miss Addr: 0x4ed80
245: Load_Miss Addr: 0x380	293: Load_Miss Addr: 0x380	298: Load_Miss Addr: 0x380
246: Load_Miss Addr: 0xd80	294: Load_Miss Addr: 0xd80	
247: Load_Miss Addr: 0xe00	295: Load_Miss Addr: 0xe00	
248: Load_Miss Addr: 0xa80	296: Load_Miss Addr: 0xa80	
249: Store_Miss Addr: 0x50280	297: Store_Miss Addr: 0x50280	299: Store_Miss Addr: 0x50280
250: Store_Miss Addr: 0x50240	298: Store_Miss Addr: 0x50240	300: Store_Miss Addr: 0x50240
251: Load_Miss Addr: 0x5d300	299: Load_Miss Addr: 0x5d300	301: Load_Miss Addr: 0x5d300

Fig. 3. Simulated Prime & Probe Attack: False hits and false misses obfuscate cache misses and timing.

can be held for longer periods of time but can lead to higher silicon area and consume more power. We found that even a small Guard Cache (1 KiB or 2 KiB at L1 level and 2 KiB to 4 KiB at L2 or LLC levels), is sufficient to prevent several types of side-channel attacks.

We create *false misses* by randomly evicting cache lines. On every L1-D (or L2) cache access that is a hit, we select a cache line randomly and evict the selected data based on the *eviction frequency* but do not place it in the Guard Cache. We varied the *eviction frequency* from 5% to 40%. The random evictions lead to performance losses but if the percentage of evictions is kept around 10% (which is sufficient to prevent currently known side channel attacks), the loss is reasonable (in the order of 33%) compared to turning off speculation completely. Additionally, if the random evictions are used only when in *Safe Mode* the performance losses can be reasonable. For example, if the random evictions are in place only for 10% of an application execution, assuming an attack will only last that long or critical sections constitute only 10% or execution times, the performance loss is only 2% (see Fig. 11). The false misses will make attacks using such techniques as Evict & Time [3] and Prime & Probe [3,4] more difficult since the attacker will see many more misses than those caused by victim accesses.

Fig. 2 shows the working of the Guard Cache in the memory hierarchy. The arrow labeled “1” shows the case when the Guard Cache is not used — data evicted from the primary cache (L1, L2 or LLC) is not stored in the Guard Cache. Arrow labeled “2” indicates when a data item is evicted from a primary cache and stored in the Guard cache (used as a victim cache). The arrow labeled “3” indicates the case when the missing data is brought into the Guard cache (used as Miss Cache) and not into the primary cache. The arrow labeled “4” shows the case when false misses are activated. As described above, data from the primary cache is evicted randomly.

We can deploy both false hits and false misses together to increase the randomization of cache timing. Fig. 3 shows the results from a simulated Prime & Probe attack. The left column shows the normal mode indicating what attacker sees as cache misses caused by the victim’s code (evicting attackers primed data). The middle column shows that the attacker sees additional cache misses caused by false misses strategy (shown in red). The right column indicates the case when both false hits (using the Guard Cache) and false misses are turned on. Now some misses caused by the victim’s access, seen in the

left column, appear as hits (shown in the shaded yellow area) due to false hits.

The use of the Guard Cache causing *false hits* may prevent attacks that rely on Prime & Probe. The left-hand side of Fig. 4 shows a successful attack using a proof-of-concept code from [17]: characters of the secret key (The Magic Words) are visible. The right-hand side of the figure shows the case when a Guard Cache is used to cause false hits, and it can be seen that the attack is not successful (the characters of the secret are not visible).

Speculative attacks are based on flushing array bounds variables from caches, leading to delays in checking for out-of-bounds accesses (since the array bounds variables are not in the cache) and the attacker can rely on speculative execution to bring large amounts of out-of-bounds data to the cache during this delay. Our Guard Cache prevents such attacks since it will capture the flushed array bounds variable in Guard Cache, reducing the time for bounds check, and limiting the accesses to out of bounds data.

For attack models based on cache timing analyses, our Guard Cache and random evictions will make attacks significantly more difficult as the number of hits and misses will change. If the Guard Cache is used to capture every evicted data, an attacker may be able to deduce the size of the Guard Cache. That is why we propose to randomly change the fraction of evicted data that is stored in the Guard Cache, making it difficult for the attacker to observe the size of the Guard Cache.

As shown in the table at the bottom of Fig. 4, even a 1 KiB Guard Cache at L1-D level obscures data during a Spectre attack and prevents the attack, if the attacker is using Flush & Reload side-channel. False Misses are more effective against Prime & Probe side-channel attacks. While 6% random evictions are *less likely* to prevent this attack, 8% will *partially* mitigate the attack by obfuscating some characters, and 10% or higher rates of evictions will *prevent* the attack. However, even 6% random evictions will significantly vary cache timing, making it more difficult for the attack to be successful. These numbers are based on the specific proof of attack codes, but the sizes of Guard Caches and the frequencies of evictions can be varied to achieve desired levels of protection. Section 4.3 provides a detailed analysis of the effectiveness of Guard Cache while Section 4.4 describes the effectiveness of *random evictions*.

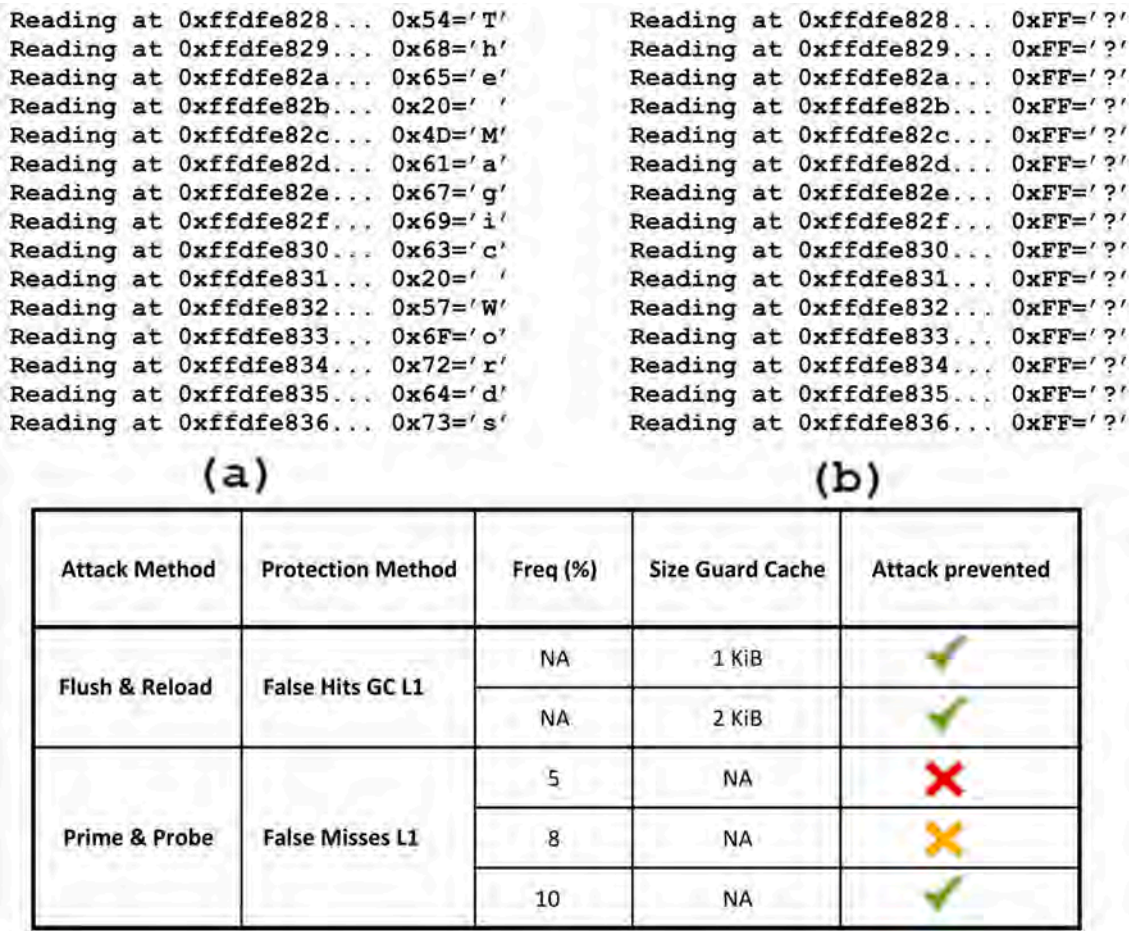

Fig. 4. Spectre attack (a) Baseline mode (b) With guard cache.

3.2. Delay speculative load misses or SafeLoadOnMiss

While False Hits and False Misses may be used to mitigate speculative attacks using proper Guard Cache sizes and random eviction frequencies, we also present a technique that delays any speculatively issued loads that miss in L1-D cache. This is similar to the one proposed in [18]; however, we queue speculative load misses in a separate queue and process the misses as soon as these loads become non-speculative, without reissuing the load request as done in [18].

3.2.1. SafeLoadOnMiss

In modern processors, the Load Store Queue (LSQ) is responsible for keeping track of all the memory/cache requests (loads, stores, cache maintenance, etc.). The LSQ (see Fig. 5) can speculatively send a load request ① to the L1-D cache for each load instruction when the corresponding address generation is complete and the load is not aligned with a previous ready-to-commit store present in the LSQ. Even though the stores can be executed speculatively, the LSQ only writes back the store requests when they become non-speculative (ready-to-commit). When there is a misprediction and the pipeline is flushed, partially/fully executed instructions (loads and stores) in the LSQ are flushed. These load requests, store requests, and other cache maintenance requests like cache flush requests are queued before the L1-D cache until the cache controller serves them. From here onward we use the term *Mandatory Queue* (Fig. 5) for the queue which holds all the requests to the L1-D cache (as implemented by Ruby coherence protocol in Gem5 [29]). The cache controller fetches the requests from the *Mandatory Queue* and performs necessary actions. When there is a cache miss, load/store request is added to the Miss Status Holding

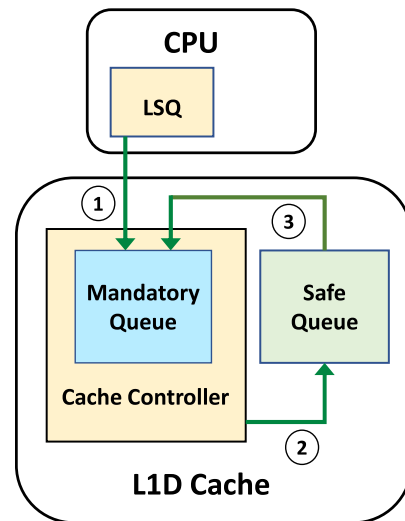

Fig. 5. SafeLoadOnMiss design.

Register (MSHR), and a new request is sent to the next level cache or the memory. The speculatively executed loads that miss the cache are responsible for bringing the secret information directly and/or indirectly when the processor is under attack.

We propose a new structure called *Safe Queue* (similar to the *Mandatory Queue*) to delay the load requests that miss in the cache. Initially,

the load request arrives at the *Mandatory Queue* ① and is read by the cache controller. When the cache controller identifies that the load is a miss, instead of adding the request into MSHR and sending a new request to the next levels of the memory hierarchy, it pushes the request to the *Safe Queue* ②. This mechanism blocks all the load misses and lets the load hits to be served by the cache controller. Since the store requests are always non-speculative, there is no need for them to be blocked even if it is a cache hit or miss. It is important to note that the *Mandatory Queue* is specific to Ruby coherence protocol in Gem5 [29] but other micro-architectures may use similar structures. *Safe Queue* is the only additional buffer required in our design apart from the minor changes to the control logic.⁴

Gem5 [29] maintains a monotonically increasing unique sequence number (1, 2, 3, 4 ...) for each instruction entering the pipeline (similar to the timestamp in Ghostminion [20]). This sequence number is also added to the metadata of all the cache requests. When the processor determines a branch misprediction and squashes (or flushes) the pipeline, the LSQ generates a new cache request called *squash request* with the sequence number of the mispredicted branch instruction. When the cache controller receives the *squash request*, it drops all the load requests which have a higher sequence number than the mis-predicted branch from both *Safe Queue* and *Mandatory Queue*.

When there is a non-speculative load that is a miss (true program misses), the processor stalls because the load request is blocked in the *Safe Queue*. To release the load, we generate another new cache request called *non-speculative request* with the sequence number to communicate that the load is safe to be served. The LSQ generates the *non-speculative request* whenever the load instruction becomes the ROB head (i.e., becomes non-speculative). When the cache receives the *non-speculative request*, it moves the corresponding load from *Safe Queue* to the top of the *Mandatory Queue* ③. This will ensure that the load is served as quickly as possible to reduce the stalling time. The determination of the load request being non-speculative can also take advantage of Bell and Lipasti conditions [31] rather than waiting for the load to reach the head of ROB. This helps moving requests from the *Safe Queue* to *Mandatory Queue* sooner and slightly improve the performance. Each entry in the *Mandatory Queue* maintains a flag to indicate whether it is speculative or not. The cache controller allows the requests to proceed if the flag is set to “non-speculative” even if it is a load miss. When a request is moved from *Safe Queue* to *Mandatory Queue* upon a *non-speculative request*, the flag is set to “non-speculative” to avoid possible deadlock.

By using the above mechanism, we avoid any changes to the cache state by the speculative load misses and block the attacker from bringing secret information to the cache. In [18], the authors propose to drop the load misses and allow the LSQ to retry later. The repeated tries may lead to uneven delays in processing correctly predicted loads that miss in the cache. This may explain in part why the performance losses reported in [18] are higher than those reported in this paper. In the rare case when the *Safe Queue* is full, load misses are dropped and the LSQ must retry when the resources are available (similar to the mechanism when the MSHR is full). As we show in Section 4.8, even a small 16 entry *Safe Queue* is more than adequate to track speculative load misses for SPECspeed 2017 benchmarks. Thus, it is very unlikely that the *Safe Queue* will be full.

3.2.2. Real-time attack detection

Speculative execution attacks rely on widely known cache side channels such as Flush & Reload [5] and Prime & Probe [3,4] to infer the secret information. The Flush & Reload side channel has a higher reliability and less noise compared to Prime & Probe and is often used in most speculative attacks [32]. We observed that the Flush & Reload

uses an excessive number of cache flush instructions (CLFLUSH in X86, MCR in ARM) and it can be used as an indicator of an attack underway. Instruction address and permission bits can be used to distinguish a cache flush used by an attacker and system activities (e.g. TLB shoot-down). Innocuous user programs rarely use cache flushes and if it does, the program will trigger a false positive. This detection technique can be improved using (off-line) machine learning algorithms to identify the nature and frequency of flush instructions occurring when an attack is underway, including the likelihood of the same cache line/set being flushed repeatedly, and higher L2/L3 cache occupancy. In this paper, we utilize a more conservative and simple approach to detecting an attack whenever a cache flush request is present. Evaluating different detection techniques published in the literature for their suitability for real-time attack detection and accuracy of detection is left as future work.

3.2.3. Alternate between safe and unsafe modes

As explained in Section 3.2.2, when an attack is detected or when Enter_Safe_Mode() call is made, a register/flag is updated to indicate that the system is switched from *UnsafeBaseline* to *SafeLoadOnMiss*. The L1-D cache will start moving all load misses to the *Safe Queue* and the LSQ starts generating necessary *squash* and *non-speculative* requests to remove or release load misses. Our experiments with the Proof of Concept attack presented in [17] (see Listing I, in Section 2) showed that waiting in the *SafeLoadOnMiss* mode for 1000 committed instructions and switching back to *UnsafeBaseline* after detecting an attack if no additional cache flushes occurred is sufficient to successfully avoid the attack.

When switching from *SafeLoadOnMiss* to *UnsafeBaseline*, L1-D cache stops any new load misses being placed in *Safe Queue*. However, the LSQ keeps generating *squash* and *non-speculative* requests until the *Safe Queue* becomes empty. A system register is maintained to indicate the number of valid entries in the *Safe Queue*. It is also possible to immediately remove all *Safe Queue* entries when switching from safe to unsafe and slightly improve the performance. However, this may increase the hardware overhead for the *Mandatory Queue* (see Section 4.8) and the complexity of the design. When the *Safe Queue* becomes empty, the system fully recovers from the *Safe Mode* and continues working under high performance (and unsafe) mode. This mechanism allows us to easily switch back and forth without significant overhead which is one of the main goals of the *SecurityCloak* framework.

3.2.4. Random replacement policy

In the baseline *UnsafeBaseline* mode, we use the Tree-PLRU [33] replacement policy (default policy of Gem5 [29] Ruby caches) for all cache levels. However, the LRU based replacement variants are susceptible to attacks such as Speculative Interference [19]. The attacker can exploit the replacement state changes (e.g. loads reordering) made by the speculative execution to indirectly recover or infer secret information. We use random replacement policy at L1-D cache and L2 shared cache levels to mitigate such attacks. Table 2 shows the average performance loss for SPEC2017 benchmarks when the random replacement policy is used for the baseline (*UnsafeBaseline*) system compared to using Tree-PLRU replacement policy. As can be seen, the use of random replacement policy does not cause a significant performance loss and since we use the random replacement policy only in *Safe Mode*, the performance loss due to random replacement will be even less.

When the system detects an attack and switches from *UnsafeBaseline* to *SafeLoadOnMiss*, cache replacement policy is also changed from Tree-PLRU to random. When the system exits *Safe Mode*, the cache replacement reverts to Tree-PLRU. This switching between the replacement policies may obfuscate some side-channel attacks that depend on cache meta-data.

⁴ Although our implementation is based on Ruby system in Gem5, our approach of using a *Safe Queue* can be implemented in any microarchitecture.

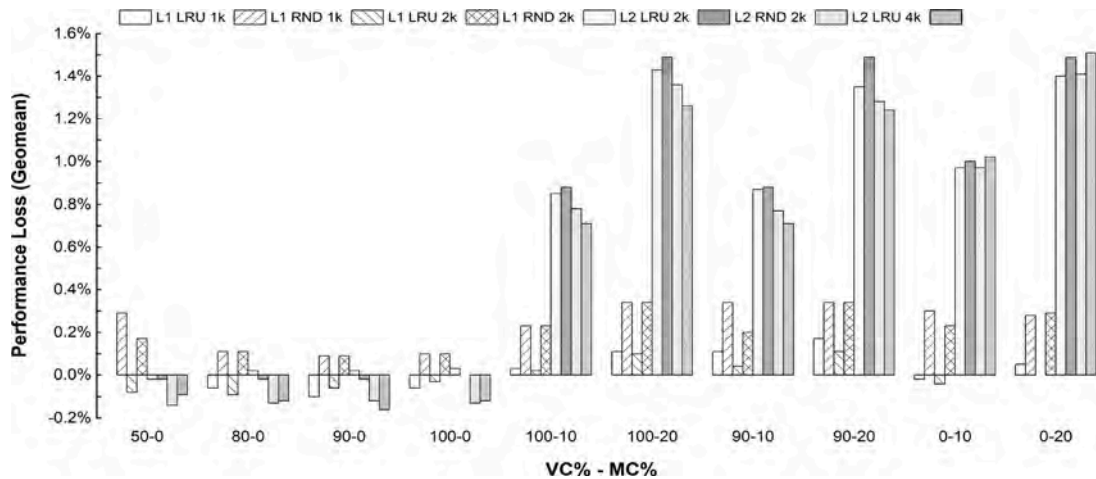

Fig. 6. Guard cache used as a victim cache and miss cache. X-axis designates the fraction of the evicted lines that are moved to guard cache (VC%) and the fraction of demand misses that are brought to guard cache (MC%).

Table 2

Average performance loss due to random replacement policy compared to Tree-PLRU.

Configuration	Slowdown (%)
L1-D Random replacement	0.3
L2 Random replacement	3.2
Both together	3.4

Table 3

System configuration.

System configuration.	
Core	
Core	1-core Out-of-order, no SMT, 2 GHz
Pipeline	192-entry ROB, 64-entry IQ, 32-entry LQ, 32-entry SQ, 256 Int/256 FP registers
Tournament Predictor	2-bit, 2048-entry local, 8192 global, 8192 choice, 4096 BTB, 16 RAS
Caches	
L1-I Cache	32 KiB, 4-way, 2-cycle latency
L1-D Cache	64 KiB, 8-way, 2-cycle latency
L2 Cache	2 MiB, share, 16-way, 20-cycle latency
Coherency	Directory based MESI Ruby protocol
Rest of the System	
Memory	DDR3_1600_8 × 8, 8 GiB
Safe queue	64 entries
Mandatory queue	64 entries

4. Experimental evaluation

In this section, we describe our experimental setup and evaluation of our techniques for mitigating side-channel attacks and attacks based on speculative execution. Our techniques were described in Section 3.

4.1. Experimental setup

We evaluate our design using Gem5 [29] System-call Emulation (SE) mode to accurately model the high performance X86 system showed in Table 3 (similar to prior works [16,17,20]). We implemented all the features described in Section 3 and in this section we will include an evaluation of our *SecurityCloak* framework. For this contribution, we focused on a single core. However, we are confident that the approach can be extended to multicore systems and multiple levels of caches. We will investigate the multicore implementations in our future work.

Table 4

Workload characteristics.

Workload	Branch missprediction rate (%)	L1-D cache miss rate (%)	Branch MPKI	L1-D MPKI
bwaves	1.38	0.01	0.00	3.95
cactuBSSN	0.63	0.93	0.30	2.98
deepsjeng	0.07	6.28	6.88	0.28
exchange2	0.00	3.69	4.27	0.00
fotonik3d	0.01	1.86	4.61	0.05
gcc	2.49	4.22	9.87	9.61
imagick	1.73	0.02	0.02	7.38
lbm	6.40	3.09	0.15	21.36
leela	0.04	2.90	4.42	0.15
mcf	3.37	5.29	10.73	15.51
roms	3.45	0.20	0.06	11.60
wrf	0.89	1.29	0.39	2.97
x264	0.02	0.12	0.06	0.06
xz	0.06	7.91	5.80	0.25

4.2. Workloads

In our experiments, we use 14 SPECspeed 2017 benchmarks with the *reference* data set. We forward the execution by 10 billion instructions to generate the checkpoint and simulate 500 million instructions. Important characteristics of the workloads are shown in Table 4. As discussed in Section 2, Branch Misprediction Rates and L1-D Cache Miss Rates play a significant role on the performance lost due to any security protection mechanism. For our mitigation technique of delaying speculative cache misses, higher L1-D miss rates correlate to higher performance loss since more load instructions will be delayed until the speculation is resolved. Likewise, higher number of branches and lower branch mispredictions can impact the performance lost since more branches cause more speculations and when the misprediction is low, delayed load instructions will need to be completed. To better understand the absolute number of branch mispredictions and load misses present in the workload, we include the MPKI (Misses/Mispredictions Per Kilo Instructions) values in Table 4.

4.3. Analysis of false hits:

In Section 3.1 we have shown that even a small Guard Cache (1 KiB or 2 KiB at L1 level) can prevent attacks that rely on Flush and Reload side-channels. Here we present the performance impacts caused by our Guard Cache for several different SPEC 2017 benchmarks. We

Benchmark	Baseline				L1 Misses that are found in GC1		L2 Misses that are found in GC 2	
	L1-D accesses per 1000 instructions	L1-D Misses per 1000 instructions	L2 accesses per Million instructions	L2 Misses per Million instructions	1KiB GC1	2KiB GC1	2KiB GC2	4KiB GC2
<i>bwaves_s</i>	286.80	3.95	3955.43	3952.57	0	0	0	0
<i>cactuBSSN_s</i>	474.63	2.92	96860.32	288.84	1362096	1378503	0	0
<i>deepsjeng_s</i>	402.52	0.28	6853.09	115.76	4877	7752	4	4
<i>exchange2_s</i>	158.94	0.00	7.28	2.57	0	0	0	0
<i>fotonik3d_s</i>	395.64	0.05	3146.18	44.52	0	0	0	0
<i>imagick_s</i>	425.87	7.38	7392.09	294.19	151	322	0	0
<i>lbm_s</i>	333.96	21.36	21445.10	13027.49	34	56	1	2
<i>leela_s</i>	361.94	0.15	979.39	8.79	6104	11145	0	0
<i>mcf_s</i>	459.63	15.51	15393.62	5692.01	52734	96158	767	1472
<i>roms_s</i>	335.88	11.60	11610.84	6499.45	646139	2221141	6	7
<i>wrf_s</i>	331.86	2.97	3417.83	28.36	5140	9893	0	0
<i>x264_s</i>	362.58	0.06	1174.48	50.09	28	83	0	0
<i>xz_s</i>	383.38	0.25	349.82	176.36	1123	2594	6	10
Geomean	351.78	0.71	3090.07	228.87				

Fig. 7. Additional cache hits due to guard Cache.

varied the Guard Cache sizes: 1 KiB–2 KiB at L1-D level and 2 KiB–4 KiB at L2 level. In Section 3.1 we have shown that even these sizes are sufficient to prevent attacks that rely on Flush and Reload side-channels and these sizes for Guard Caches require very small additional hardware. We varied the fraction of the time a data item that is evicted from the primary cache (L1-D or L2) is moved to the Guard Cache: the first number for each result in Fig. 6 shows this percentage. We varied how often the Guard Cache is used as a Miss Cache; that is, on a demand miss, the missing data is brought in to the Guard Cache, and no data is evicted from the primary cache. The second number for each result in Fig. 6 shows this percentage. Thus, 90-10 shows the results when 90% of all evictions from the primary cache are moved to the Guard Cache (used as victim cache), and 10% of demand misses are brought into Guard Cache (used as miss cache). As can be seen, the results in Fig. 6 show very minimal impact on performance ranging between -0.2% to 3.0% performance loss. Negative bars indicate performance gains — LRU replacement policy for primary caches results in performance gains than when Random Replacement is used. The use of Guard Cache as a Miss Cache results in slightly higher performance losses than when used as a victim cache.

Fig. 7 shows some memory access behaviors of applications including average number of data accesses per 1000 instructions and average number of cache misses per 1000 instructions (first four columns in the figure). The figure also shows the average number of L1-D and L2 cache misses that are satisfied by the Guard Cache per 1000 instructions executed. Guard Cache is likely to result in performance benefits when the application exhibits higher cache conflicts; this can be seen from a higher percentage of *false hits*. Consider *cactus* with 2.92 L1-D misses per 1000 instructions without a Guard Cache and a Guard Cache of even 1 KiB effectively eliminates these cache misses (shown as false hits). This also indicates that most side-channel attacks such as Flush & Reload that rely on observing which accesses cause misses will fail because most of such cache misses (or Flushes) become invisible with use of the Guard Cache. We have already demonstrated (see Fig. 3 in Section 3) that Guard Cache makes many of the L1-D evictions caused by Prime & Probe attack invisible.

The benchmark *lbm* has very high L1-D miss rates (21.36 misses per 1000 instructions at L1-D), but these misses are not satisfied by Guard Cache. Such a behavior may potentially indicate that the application is a streaming application. Fig. 7 shows false hits data for different Guard Cache sizes. Although not shown here, we observed that most applications see very insignificant performance impact due to Guard Caches that are larger than 4 KiB or 8 KiB. But applications with higher number of data accesses place higher demand on Guard Cache and larger Guard Caches may be more beneficial for such applications. For example, *roms* appears to benefit from larger Guard Cache (more *false hits* with larger Guard Cache). This behavior may indicate capacity misses since the application shows high MPKI (11.6 misses per 1000

instructions), but 1 KiB Guard Cache shows very minimal benefit. Since our goal is prevention of attacks and not improved performance, we feel 1 KiB or 2 KiB Guard Caches are sufficient.

Fig. 7 also includes additional cache hits due to Guard Caches at L2 level. The L2 cache misses that are found in L2 level Guard Cache is very small. This is expected since there are fewer memory accesses and misses at L2 level. Moreover, it should be noted that we use Random Replacement policy with our Guard Caches. This means that a data item evicted from the primary cache and moved to the Guard Cache may be evicted later when another data item evicted from the primary cache needs space in the Guard Cache and Random Replacement policy may cause more recently evicted item to be replaced in the Guard Cache.

We feel that the hits in Guard Cache (which were misses in the primary cache) may be used as a way to detect Flush & Reload type attacks since the attacker hopes to create many misses while GC captures the evicted data.

The data in Figs. 6 and 7 are collected with no side channel attack. However, when an attack such as Prime & Probe, Flush & Reload or Evict & Time is underway, the GC will have higher impact on performance. These attacks result in higher levels of cache misses, many of which will be caught by the Guard Cache. For example, for simulating a proof of concept attack representing Flush & Reload as well as Spectre attack (the same attacks that we used to produce Figs. 3 and 4), 1 KiB Guard Cache at L1-D resulted in more than 100% additional cache hits.

4.4. Analysis of false misses

Before we present the performance impact of randomly evicting cached data on SPEC 2017 benchmarks, we present how and when random evictions can be effective. We use the Proof of Concept (PoC) code shown in Listing I to simulate Spectre attack. The PoC code assumes that the attacker knows the range of addresses where the victim's secret is stored. The attacker injects code into victim's program to force misprediction of array size accessed by the victim, forcing accesses to a range of addresses where the key is stored. If the victim accesses an address containing the key in the mispredicted path, that item will be brought into (L1D) cache. For the purpose of the PoC attacks, the key is considered as 40 ASCII characters.⁵ When a character in the key is fetched by the victim, the attacker injected code uses the value of the character (i.e., 8-bit value) as index to a 256-element array and stores a value. Later the attacker checks which one of his 256-element array contains a value and this in turn is used as the key (character) accessed by the victim. The attacker can use either a Prime & Probe or Flush & Reload side-channel to find the key.

4.4.1. Using Prime & Probe side-channel

If Prime & Probe is used, attacker first “primes” (or fills) the 256 entries of his array. When victim accesses a character in the key, and that key (8-bit ASCII) is used as index into the attacker's array by the victim program, one of the attacker's array elements will be invalidated (assuming both attacker and victim share the address space and MESI type coherence protocol is used). When the attacker “probes” and encounters an invalidated array element, he/she can discover the value of the character accessed by the victim. The main observation here is that the attacker is searching for misses among his (256) array elements. Our random evictions can mitigate the attack by causing more misses among attacker array characters. The obfuscation will occur only if the randomly evicted cache lines are among the (256) array elements that will be primed and probed by the attacker. This in turn depends on the total size of the cache and the portion of the cache that will be occupied by the attacker's array. In our experiments, the total size of the cache is 1024 lines (for a 64 KiB cache with 64 bytes per

⁵ Although the attack contains 40 characters, we have shown only 15 characters “The Magic Words” in Fig. 4.

Attack Method	Protection Method	Set Freq (%)	Minimal Cache Evictions	Average Cache Evictions	Minimum number of attempts needed to discover key	Geomean SPEC 2017 Benchmark performance Loss (%)	Attack prevented
Prime & Probe	No Protection	0	1	1	1	0	✗
	False Misses	5	41	53	4	14	✗
		8	61	81	6	24	✘
		10	83	99	7	33	✓
		15	133	150	12	59	✓
		20	179	194	22	90	✓
		25	215	228	55	120	✓
		30	241	248	248	150	✓
		35	252	255	NA	180	✓
		40	256	256	NA	209	✓

Fig. 8. Random evictions (False misses) at different eviction frequencies in L1D cache. The minimal cache misses evicted are the randomly evicted cache lines that attacker encounters as misses which can mitigate the chance of a successful attack.

Benchmark	Performance Loss(%)								
	L1D Freq 5%	L1D Freq 10%	L1D Freq 15%	L1D Freq 20%	L1D Freq 30%	L1D Freq 40%	L2 Freq 5%	L2 Freq 10%	L2 Freq 15%
bwaves_s	39	84	142	201	300	371	0	0	0
cactuBSSN_s	1	6	25	74	237	389	29	57	118
deepsjeng_s	7	17	32	50	91	131	2	5	12
exchange2_s	4	9	15	24	49	85	0	0	0
fotonik3d_s	3	8	13	20	41	80	2	5	12
imagick_s	29	99	207	330	507	672	1	6	15
lbm_s	-2	12	62	118	211	277	1	2	3
leela_s	5	14	19	25	48	86	1	1	3
mcf_s	3	12	33	64	123	184	1	1	3
roms_s	54	105	146	181	237	278	0	0	0
wrf_s	24	69	118	175	274	392	5	8	14
x264_s	14	36	59	84	132	176	0	1	2
xz_s	8	15	22	32	51	71	0	0	0
Geomean	14	33	59	90	150	209	3	6	11

Fig. 9. Average performance loss using random evictions (FalseMiss Scheme) at different eviction frequencies in L1D and L2 Caches.

line) and the attacker uses one-fourth (256) of these lines. A random eviction has a 25% probability that an attacker's data is evicted. To be successful in preventing the attack, we need to evict multiple cache lines belonging to the attacker.

To understand the relationship between the random eviction frequency and the fraction of total cache that the attacker primes and later probes (we call this *cache occupancy*), consider an extreme case where the attacker primes only 2 cache lines, assuming that the key is one of two different characters. If the cache contains 1024 lines, there is only one-in-512 (or 0.002) chance that a random eviction removes one of the two attacker's cache lines. The probability that we can randomly evict both attacker cache lines so that the attacker will not be able to find the correct key is at most $1/(512 \times 512)$ but likely much lower as a random eviction may evict the cache line multiple times. On the other hand, consider the case where the attacker primes and probes 1024 cache lines (the entire size of the cache). Every random eviction will evict an attacker's data making it very easy to prevent attacks.

Fig. 8 shows more details about the effectiveness of random evictions for different eviction rates. The column "Minimal Cache Evictions" indicates the minimum number of random evictions that fall within the attacker's 256 cache lines. The attacker repeats the Prime & Probe process 5 times for each character. Since only the cache line accessed by the victim will evict attacker data, repeating Prime & Probe

process improves the confidence in the key detected. To prevent the discovery of the key, our random evictions must also repeatedly evict the same cache lines (besides the key). This is likely to happen if the "Minimal Cache Evictions" is high. As can be seen at 10% random eviction frequency, at least 83 of the attacker's data is evicted on every attempt, and for the given Proof of Concept this appears to be more than sufficient to completely prevent the attack. However, at 8% frequency, attacker was able to discover some of the characters in the key but not all. It should also be noted that the attack may be successful even at 10% evictions if the Prime & Probe process is repeated more than 7 times for each character. At higher random eviction frequencies (say at 30% or 40%), the minimal cache misses encountered by the attacker reaches 256 (all of attacker's data), and the attacker is unlikely to succeed even after numerous attempts.

Another data included in Fig. 8 is how the difficulty presented to the attacker increases when random evictions are used. The sixth column shows the minimum number of times the attacker must repeat the Prime & Probe to discover the victim's key characters. As we stated previously, the Proof of Concept attack repeats the Prime & Probe 5 times to discover each character (a total of 200 times to obtain the full 40-character key). But the data in Fig. 8 shows that as the random evictions are used, the attacker must repeat the Prime & Probe many more times. For example at 10% random eviction rate, the

Benchmark	Baseline		Additional L1 MPKI		
	L1-D Accesses per 1000 instructions	L1-D Misses per 1000 instructions	L1D Freq 5%	L1D Freq 10%	L1D Freq 20%
bwaves_s	286.80	3.95	15.05	43.85	127.00
cactuBSSN_s	474.63	2.92	22.40	50.36	184.13
deepsjeng_s	402.52	0.28	20.04	42.02	92.87
exchange2_s	158.94	0.00	8.10	16.53	37.98
fotonik3d_s	395.64	0.05	19.65	39.73	80.30
imagick_s	425.87	7.38	21.18	61.04	192.48
lbm_s	333.96	21.36	0.99	25.27	90.56
leela_s	361.94	0.15	29.81	38.02	95.27
mcf_s	459.63	15.51	14.89	41.81	200.91
roms_s	335.88	11.60	24.17	42.05	104.91
wrf_s	331.86	2.97	16.31	43.48	123.58
x264_s	362.58	0.06	19.41	42.14	89.32
xz_s	383.38	0.25	19.09	40.77	93.45
Geomean	351.78	0.71	14.68	38.92	106.94

Fig. 10. Additional L1 misses per kilo instructions for different frequencies of random evictions.

attacker must try Prime & Probe at least 7 times to discover a character (at least 280 times for 40-character key). We emphasize that this is the minimum and it often takes many more tries since evictions will randomly evict different cache lines. At random frequencies higher than 30%, the number of tries needed quickly and exponentially increases. This is because, as stated previously, at these frequencies, attacker sees cache misses (repeatedly) in all the cache lines he/she primed due to random evictions, making it almost impossible to single out the character that is part of the key. Thus, random evictions either prevent the attack or make it much more difficult for the attack to succeed. While higher random eviction frequencies aid in the prevention or mitigation of attacks, since the performance loss increases with higher frequencies, one should rely on such higher random evictions only for critical code sections as we will describe later in this section and shown in Fig. 11.

In summary, the number of cache lines used by the attacker in relation to the total size of the cache (or *cache occupancy*) and the number of times an attacker repeats the priming and probing determines the random eviction frequencies needed to successfully obfuscate the attack. Additionally, since in our implementation, we only consider (random) evictions on a cache hit, the probability of evictions also depends on the cache hit rates. For example, when the random eviction frequency is very high, our method evicts most of the cache lines, causing fewer hits, and this in turn, reduces the probability of further evictions. In our experiments, frequencies higher than 30% lead to the eviction of most, if not all, of attacker's 256 array elements. Additional evictions can only evict the attacker's data repeatedly and lead to no further obfuscation.

4.4.2. Using Flush & Reload side-channel

The attacker can also use Flush & Reload side-channel attack to discover this key. In this method, the attacker flushes his/her (256) array elements (in addition to flushing array size as described in Section 2). When the attacker injected code makes the victim access one of these array elements using the key character as an index, a cache line of the attacker array will be filled and becomes valid. The attacker reloads each of 256 array elements to see which of his/her array elements causes a hit to discover the key. Once again, the attacker repeats the experiment several times to be confident of the array element that was accessed by the victim. For our random evictions to be successful, we need to evict the array element accessed by the victim, after the victim accesses it but before the attacker checks (this would cause a miss when the attacker reloads the data). This requires a very high frequency of random evictions. As we have shown, higher eviction frequencies can

lead to excessive performance loss. But using Guard cache as a victim cache can prevent Flush & Reload based attack as shown in Fig. 4. The data flushed by attacker will be captured in the Guard Cache and when the attacker reloads the data, most, if not all, array elements appear to be hits, thus obfuscating the discovery of victim's key characters.

4.4.3. Performance impact of false misses

We now present the performance impact of random evictions. Fig. 9 shows the performance loss for SPEC 2017 benchmarks when cache lines are randomly evicted. On every cache hit (either at L1-D or L2), we decide if a random cache line should be evicted based on the *eviction frequency*. The data in Fig. 9 is for different *eviction frequencies*. A higher frequency of evictions will cause higher performance losses. For example, if a cache line is evicted 20% of the time a L1-D cache access is a hit, we see a geometric mean performance loss of 90% for SPEC 2017 benchmarks. This is an unacceptable performance loss; however, it can cause significant obfuscation of cache access times. As previously shown in Fig. 4, 10% frequency of random evictions is adequate to cause sufficient obfuscation to prevent Prime & Probe side-channel attacks. A 10% random eviction frequency leads to a 33% geometric mean performance loss for SPEC 2017 benchmarks. In our experiments, we evicted both modified and unmodified data from caches. The performance loss due to random evictions can be minimized if only unmodified data is selected for random evictions. However, an attacker may circumvent the impact of random evictions by repeatedly writing the same data.

Fig. 9 shows that the performance loss at L2 due to random evictions is significantly smaller since there are significantly fewer accesses to L2. We only select cache data for eviction when L2 cache is accessed and the access is a hit.

Fig. 10 shows additional cache misses per 1000 instructions encountered by applications that are caused by random evictions. The figure also includes L1-D cache accesses per 1000 instructions and cache misses for 1000 instructions in the baseline (without random evictions). Since we apply random evictions on every (L1-D) cache hit, higher cache hits in the baseline can lead to more frequent random evictions. On the other hand, applications that have higher miss rates will likely see less impact due to random evictions as fewer additional cache misses will be encountered by the applications. Streaming applications may not see the effects of false misses since the randomly evicted data may not be accessed by the application. Random evictions may even be beneficial for such applications since when a truly missing data needs to be brought into the cache, there is no need to find a Least Recently Used cache line for replacement as the cache contains many invalid entries. Consider *lbm* and *wrf_s*, both have about the same number of L1-D accesses per 1000 instructions, (see Table 4) but *lbm* has higher miss rate (MPKI of 21.36 compared to 2.97 for *wrf_s*). With higher hit rates (and lower miss rates) *wrf_s* encounters additional cache misses with random evictions. The benchmark *lbm* with higher miss rates and lower hit rates encounters fewer additional misses caused by random evictions. The application *mcf* has higher L1-D accesses and higher miss rates which explains the higher number of additional cache misses encountered by the application. The benchmark *exchange2_s* has fewer L1-D accesses but very low miss rates — indicating that most of the accesses are hits which causes a higher number of random evictions. It should be remembered that higher false misses can aid in further mitigating side-channel attacks.

4.4.4. Using random evictions only when needed

Since high random eviction rates can cause significant performance losses, this method should be used only when needed, for example, to protect critical code sections or when an attack is detected. To simulate *turning on* protection only when needed we experimented by *turning-on* false misses (or random evictions) only for a fraction of the application execution time. For example, when the false miss strategy is enabled 10% of the execution time of an application, false misses are introduced

Protection activation time (%)	Performance Loss(%)		
	L1D	L1D	L1D
	Freq 5%	Freq 10%	Freq 20%
10	1	2	7
50	4	11	36
100	14	33	90

Fig. 11. Performance loss when random evictions at L1-D are activated only for a portion of application execution times.

Table 5

Execution times using different mitigation techniques for SPECspeed 2017 benchmarks, normalized to unprotected (*UnsafeBaseline*) baseline.

Workload	<i>NoSpeculation</i>	<i>SafeLoadOnMiss</i>	<i>SafeLoadOnMiss</i> + Random replacement
bwaves	1.3326	1.0000	1.0822
cactuBSSN	1.1003	1.0168	1.0180
deepsjeng	1.6377	1.0040	1.0051
exchange2	2.7800	1.0000	1.0000
fotonik3d	4.3716	1.0000	1.0001
gcc	3.0320	1.0895	1.1353
imagick	2.3592	1.0362	1.0423
lbm	1.2668	1.0002	1.1264
leela	2.0863	1.0003	1.0007
mcf	2.1056	1.1127	1.1874
roms	2.1474	0.9997	1.1354
wrf	1.6129	1.0343	1.0424
x264	1.4440	1.0014	1.0016
xz	1.3315	1.0031	1.0032
Geomean	1.8956	1.0213	1.0539

for 50 million instructions (out of 500 million instructions simulated in our experiments). Fig. 11 shows the geometric mean performance losses for the SPEC 2017 benchmarks. As can be seen, if random evictions are applied only 10% of the applications' execution, we only see a geometric mean performance loss of 5% at 10% random eviction rate at L1-D level (not 62% if the random eviction are turned on during the entire execution). Even when *false misses* are introduced for half of the application execution, the geometric mean performance loss is 26% at 10% random eviction rate. We feel that security protection should be used only when needed — to protect critical segments of applications which minimizes performance losses.

4.5. Combined analysis

In the final set of experiments, we used both Guard Cache (i.e., *false hits*) and random evictions (i.e., *false misses*). The performance losses are similar to those when only *false misses* are in place. The performance impact of Guard Cache was negligible. The results are very similar to those shown in Fig. 9.

4.6. Evaluation of *SafeLoadOnMiss* technique

Table 5 shows the normalized execution times with respect to *UnsafeBaseline* (that does not rely on any mitigation techniques) for (i) *NoSpeculation*, whereby speculative execution is disabled, (ii) *SafeLoadOnMiss* using LRU replacement policy and (iii) *SafeLoadOnMiss* with random replacement policy. TreePLRU replacement (default in Gem5 [29] Ruby) policy is used in all cache levels in *UnsafeBaseline*, *NoSpeculation* and *SafeLoadOnMiss* modes. Here, the *Safe Mode* is on for the entire execution duration of applications.

As expected, completely restricting the speculation results in high-performance loss: 89.6% on average. It should be observed that *fotonik3d* has a very low branch misprediction rate (see Table 4)

leading to significant performance loss when speculation is disabled. On the other hand, *mcf* has high branch misprediction rates and thus preventing speculation leads to lower performance losses. When the cache MPKI is low but branch MPKI is high, the performance loss will be lower. Disabling speculation completely does provide protection against all speculative attacks but it cannot be justified because of the excessive performance losses.

Table 5 also shows that delaying speculative load misses (*SafeLoadOnMiss*) with and without the random replacement policy results in very small performance penalties of 5.4% and 2.1% respectively. Even though the use of random replacement policy increased the performance loss, it will improve the attack coverage by mitigating threats such as Speculative Interference attack [19] (as detailed in Section 3.2.4). Although *fotonik3d* and *exchange2* have lower misprediction rates, they also have lower L1-D MPKI. This means fewer delays for load instructions in speculative execution, leading to almost negligible performance loss. The benchmark *bwaves* has no significant loss due to extremely low branch misses (Branch MPKI = 0.00). On the other hand, higher branch MPKI and cache miss MPKI values lead to higher performance losses for *mcf* and *gcc*. Even though *lbm* has the highest L1-D MPKI value, its low branch MPKI was able to balance out the performance penalty by utilizing the instruction level parallelism. In summary, *SafeLoadOnMiss* performs poorly when both branch mispredictions and L1-D misses are high and having a lower value for either one of the miss parameters seems to cancel out the performance effect. Adding the random replacement policy on top of *SafeLoadOnMiss* showed an extra slowdown of 3.3% (5.4%-2.1%) which aligns with the performance loss added to the *UnsafeBaseline* (3.4%, see Table 2).

4.7. Switching between safe and unsafe modes

Launching attacks while running a real application such as SPEC-speed benchmark is very difficult and may require modifications to benchmark codes (which is not recommended). Finding a real world working Spectre attack example capable of doing actual damage is out-of-scope for this research. To emulate the attack environment (either to protect critical code sections or when an attack is detected), we enter the *SafeLoadOnMiss* mode for 10%, 20%, and 30% of the time and switch back to *UnsafeBaseline* the rest of the time. To avoid catching a specific section of the workload where the load miss activity or the branch activity is low, we distribute the partial *SafeLoadOnMiss* modes (10%, 20% and 30%) uniformly across the entire execution of an application. We used 1000 equi-width chunks for each partial *SafeLoadOnMiss* mode (enter and exit *SafeLoadOnMiss* mode 1000 times) and uniformly distributes them across the 500 million instructions of the simulation window. We switch to the random replacement policy whenever we are in the *SafeLoadOnMiss* mode. Fig. 12 shows (on Y-axis) the percentage of performance loss due to the *SafeLoadOnMiss* technique when compared to an unprotected baseline system if the protection is on only for short periods of time (10%, 20%, 30% of the execution time of an application) as well as when the protection is on during the entire execution of an application (100%). As can be seen from the figure, the average performance degradations when the protection is on for only 10%, 20%, and 30% of execution of an application are 1.2%, 1.9%, and 2.5% respectively. As shown in Table 5, we see a 5.39% loss if the protection is on all the time (see Fig. 13).

4.8. Hardware overhead

As mentioned in Section 3.2.1, the only additional buffer structure required in our design is the *Safe Queue*. Each *Safe Queue* entry contains the address of the load and the corresponding sequence number. If we assume the address is 64 bits and the sequence number and additional flags (non-speculative flag, Section 3) require 16 bits, each entry is

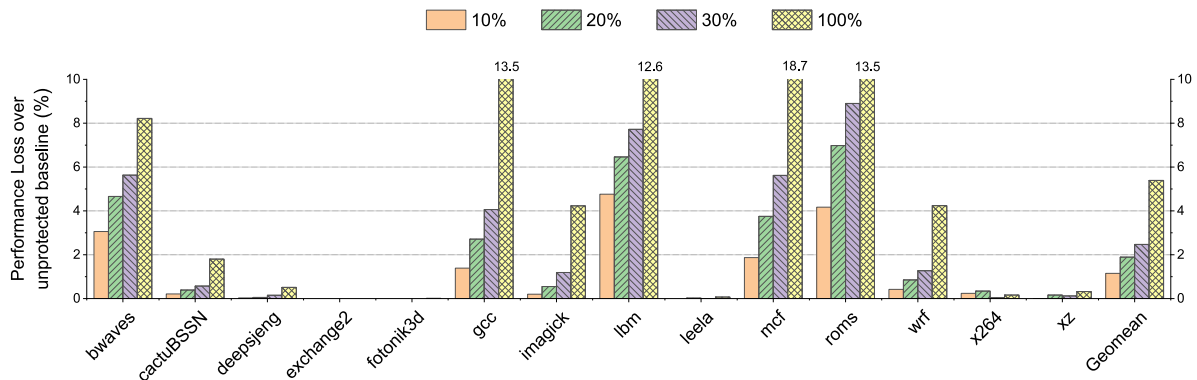

Fig. 12. Percentage of performance loss using *SafeLoadOnMiss* mitigation technique for specspeed 2017 benchmarks, normalized to unprotected (or unsafe) baseline. the data is for the cases when the *SafeLoadOnMiss* scheme is active with random replacement policy for 10%, 20%, 30%, and 100% of the total execution time.

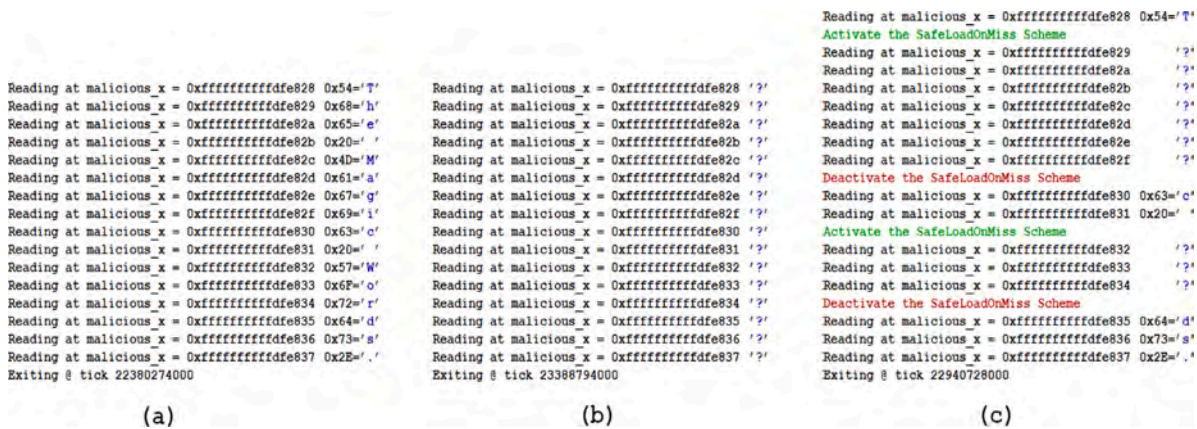

Fig. 13. On-Demand security protection. (a) The normal unsafe mode where the spectre attack is successful. (b) The *Safe Mode* is on throughout the execution and the attack is unsuccessful. (c) The *Safe Mode* is entered and exited at random intervals: Attack is prevented in *Safe Mode* but the attack is successful when the *Safe Mode* is exited.

10 bytes long.⁶ In our experiments, we observed that the maximum occupancy of the *Safe Queue* is 13 (*gcc*). The size of the *Safe Queue* should be adjusted according to the issue width of the core pipeline and the number of requests that can be served in parallel by the cache port. Thus, for our experimented design a minimum of 16 entries are enough for the *Safe Queue*. This results in an additional buffer requirement of 160 bytes, compared to Ghostminion which uses 2 KiB storage [20], CleanupSpec which uses 1 KiB [17]. Thus, the additional cost of 160B per core is significantly lower and the control logic involved in our design is easy to implement. Likewise, as shown in Section 4.3, 1 KiB to 2 KiB Guard Cache is sufficient to prevent many cache timing based attacks.

5. Related work

The research community has been very active in the area of hardware security as can be seen by numerous publications in recent premier architecture and systems conferences. Thus it is not possible to review all such works. We have already described some key publications that are very closely related to our research. We will describe some additional works that are useful in understanding the types of attacks, detecting attacks, hardware and software mitigation techniques.

⁶ Sequence number only needs to be wrapped around after twice the size of ROB (similar to timestamp in [20]). Thus, in this proposal 9 bits are enough to represent the sequence number ($192 \cdot 2 < 2^{10}$).

5.1. Types of attacks based on timing cache accesses

Based on the access latency, an attacker can deduce whether or not a cache line is in the cache through two methods to set up the cache, which in turn may reveal some information about the accesses made by a victim [3,4,22,23]. Some commonly referenced attacks include:

- Evict & Time attack [3], in which the attacker evicts a cache line triggering a miss when the victim accesses the data item.
- Prime & Probe [3,4] where the attacker “primes” by occupying all cache lines. Later the attacker probes to see which cache lines caused misses, inferring the lines accessed by the victim.
- Two variations of Flush & Reload [5] which are Evict & Reload [22] and Flush & Flush [23]

5.2. Mitigating cache side-channel attacks

In general, the solutions to protect against timing attacks are implemented to avoid sharing of caches so that attacker cannot evict the victim’s cache lines and time accesses. Another approach obfuscates how the addresses are mapped to cache sets, consequently for the attacker is more difficult to determine any portion of the addresses accessed by the victim. In Partition Locked Cache (PLCache) [34], each cache line is augmented with an ID field and a lock bit L. Dynamically Allocated Way Guard (DAWG) [11] is a mechanism to secure way partitioning of set associative caches. DAWG isolates hits, misses, and metadata updates across protection domains. There are several proposals for randomizing mapping addresses to cache sets, including Random Permutation Cache (RPCache) [14,34] and NewCache [35],

ScatterCache [15] and CHASM [36]. Ceaser [37] is another architecture based on randomized mappings, which employs a Low-Latency Block-Cipher (LLBC) to translate the physical line-address into an encrypted line-address, and access the cache with this encrypted line-address. In another approach to obfuscate cache accesses, GhostThread [38] uses a thread to interfere with both victim and attacker cache accesses.

5.3. Attacks based on speculation

The attacks that rely on speculative execution (by predicting conditional branches and/or indirect branches) are currently addressed under the umbrella of Spectre and its variants. They include:

- Spectre Variant 1 (CVE-2017-5753) [9,25,39,40]
- Spectre Variant 2 (CVE-2017-5715) or Branch target injection [9, 25,39,40]
- Spectre Variant 3 (Meltdown v3 CVE-2017-5754) [25] (CVE-2017-5754) [25], also known as Rogue Data Cache Load
- SpectreRewind [41] and Speculative Interference [19]

5.4. Mitigating speculative attacks

Software Based. Return trampoline or “Retpolines” [40,42] isolates indirect branches from speculative execution. It uses properties of the Return Stack Buffer (RSB) as a prediction structure to control speculation. Indirect Branch Control (IBC) is an architectural mechanism which has been added to the x86 ISA to help software control of branch prediction of indirect branches. It consists of 3 features: Indirect Branch Prediction Barrier (IBPB), Indirect Branch Restricted Speculation (IBRS) and Single Thread Indirect Branch Predictors (STIBP). JumpSwitches [43] is a software protection against Spectre Variant 2 with less overhead than retpolines solution. It transforms indirect calls into conditional direct calls. Conditional Speculation [44] and SpectreGuard [45] use software hints to disable speculation on sensitive instructions. New Operating Systems have added Kernel Page Table Isolation (KPTI) [46] to fix meltdown attacks, where the kernel memory space is separated from user space and uses a separate page table to prevent speculative read of kernel memory from user-space; however at the cost of an additional page table switch during every transition from user space to kernel-space and back, on every syscall instruction.

Hardware Based. There are several approaches that rely on delaying visibility of speculative accesses, including Selective Delay [18] and InvisiSpec [16]. InvisiSpec [16] uses speculative buffers for executing instructions in speculative mode, including speculative memory accesses. Upon a correct prediction, the memory accesses are reissued (hence known as “redo” technique).

A different technique, CleanupSpec [17] can be viewed as an “Undo” approach: it evicts speculatively fetched data from caches (and uses random replacement to obfuscate attacks that rely on metadata such as LRU information). Revice [30] is similar to CleanupSpec [17]: it allows speculative caching of data but hides the operation until it is safe, in part by introducing access jitters to conceal access timing. These techniques are fundamentally based on exposing or making a permanent cache state only after the Visibility Point (VP), when the instructions cannot be squashed by prior operations (that is, when the speculation is correct).

In [18], the authors propose three techniques to mitigate Spectre-like attacks. They explore two versions of delaying speculative loads that miss in the cache and a third technique that uses value prediction for load misses. Delaying load misses is similar to our technique proposed here. However, our implementation is different and our technique can be turned on when needed. We also propose random replacement policies for cache memories to make Speculative Interference attacks [19] more difficult.

Ghostminion [20] uses a separate cache like structure (Ghostminion) to hide speculative accesses and associates time stamps with the

accesses to assure both non-interference of speculative instructions with (earlier) non-speculative instructions and also visibility of (metadata) later accesses to earlier access, which can occur with out-of-order speculative executions. While this is a potentially complete solution against Speculative Interference attacks [19], it may not be easy to use for *on demand* protection.

6. Conclusion

In this paper, we presented the SecurityCloak framework — an *On Demand* protection against side-channel and speculative execution attacks. Systems can be protected by entering *Safe Mode* and turning on protection or exiting *Safe Mode* to resume normal execution. *Safe Mode* can be entered when an attack is detected or when a user wants to protect critical code sections. Any known technique to prevent (or at least mitigate attacks) can be used within our framework. However, since the main goal is the ability to dynamically *turning on* and *turning off* protection, a mitigation technique should incur minimal overheads when entering or exiting *Safe Mode*. In this paper, we rely on very simple techniques to protect against side-channel attacks such as Prime & Probe, Flush & Reload, Evict & Time, as well as Spectre and its variants that capitalize vulnerabilities resulting from speculative execution in modern computer architectures.

To mitigate cache timing attacks, we proposed and evaluated techniques to create false access times by introducing *false hits* and *false misses*. We use a small Guard Cache (a fully associative cache with very similar access latencies as the primary data caches) to cause false hits. We use Guard Cache as both a “Victim Cache” and a “Miss Cache”. We collected performance data using different Guard Cache sizes; 1 KiB to 2 KiB at L1-D and 2 KiB–4 KiB at L2 cache levels. We varied the percentage of the time the Guard Cache is activated as a Miss Cache and as a Victim Cache. We have seen negligible impact on performance, but we have shown that the use of a Guard Cache can prevent several side-channel attacks, particularly those that rely on Flush & Reload or Evict & Reload attacks.

Additionally, we randomly evict data from the primary cache, potentially causing a cache miss when a hit is expected. We have collected performance data by varying the frequency of random evictions. As can be expected, higher eviction frequencies lead to higher performance losses, but potentially greater obfuscation of cache timing. Our techniques incur very minimal hardware (small amounts of Guard Caches) and minimal complexity to vary the frequency of random evictions. Random evictions can prevent side-channels that rely on Prime & Probe attacks.

False hits and false misses can prevent or at least mitigate speculative attacks such as Spectre since Spectre attacks still rely on either Prime & Probe or Flush & Reload techniques. But we also propose an additional technique to mitigate attacks that rely on speculative loads to acquire data illegally. Our technique (labeled *SafeLoadOnMiss*) delays all speculative load accesses that miss in L1-D cache until the speculation is resolved. Our technique results in 2.1% (geometric mean) performance loss for SPEC 2017 benchmarks when the protection is on for the entire execution of benchmarks. But, the loss is only 0.2% if the protection is on for 10% of execution (assuming that an attack is active only for 10% of the execution time). To mitigate Speculation Interference attacks [19], we use random replacement policies at all cache levels when in *Safe Mode*. This causes a small amount of additional performance loss (5.3% geometric mean when protection is on 100% of the time and about 1.2% when the protection is on for only 10% of time).

Techniques proposed in this paper require minimal changes to cache memories and an insignificant increase in hardware. We use very small Guard Caches (1 KiB–2 KiB at L1 or 2 KiB–4 KiB at L2) requiring very minimal additional hardware. As we have shown, even these small Guard Caches can cause sufficient difficulty to side-channel attacks. The

hardware needed for random evictions is also minimal. The SafeLoad-OnMiss requires very small (160 Bytes) additional storage for the SafeQueue and very minimal hardware for managing the SafeQueue.

To benefit from *On Demand* protection, it is necessary to implement an attack detection method. The detection method should be efficient for real-time detection so that the system can enter *Safe Mode* without delays and prevent the attack as quickly as possible. A detection method should also result in highly accurate detection of attacks — false hits can cause higher performance losses. In this paper, we use a simple detection technique based on our observation that most side-channel attacks based on speculative executions use an excessive number of cache flushes. We conservatively enter *Safe Mode* when a cache flush instruction is executed. After an interval, based on our observations, if no additional flushes are detected, we exit *Safe Mode*.

We plan to extend the SecurityCloak framework by exploring additional security prevention techniques as well as additional detection techniques.

CRedit authorship contribution statement

Fernando Mosquera: Conceptualization, Data curation, Formal analysis, Investigation, Software, Writing – original draft, Writing – review & editing. **Ashen Ekanayake:** Conceptualization, Data curation, Formal analysis, Investigation, Software, Writing – original draft, Writing – review & editing. **William Hua:** Supervision, Validation, Visualization. **Krishna Kavi:** Conceptualization, Resources, Supervision, Validation, Visualization, Writing – original draft, Writing – review & editing. **Gayatri Mehta:** Conceptualization, Supervision, Validation, Visualization, Writing – original draft. **Lizy John:** Conceptualization, Validation, Visualization, Writing – original draft, Writing – review & editing.

Declaration of competing interest

The authors declare that they have no known competing financial interests or personal relationships that could have appeared to influence the work reported in this paper.

Data availability

Data will be made available on request.

Acknowledgments

This research was supported in part by National Science Foundation grants #1763848 and #1828105. The authors would also like to thank Tony Chen of UNT Texas Academy of Mathematics and Science (TAMS) program for collecting some of the data presented here and acknowledge the feedback received from Brandon Potter and Mike Ignatowski of AMD.

References

- [1] D.J. Bernstein, Cache-timing attacks on AES, 2005.
- [2] N. Lawson, Side-channel attacks on cryptographic software, *IEEE Secur. Priv.* 7 (6) (2009) 65–68.
- [3] D.A. Osvik, A. Shamir, E. Tromer, Cache attacks and countermeasures: the case of AES, in: *Cryptographers' Track At the RSA Conference*, Springer, 2006, pp. 1–20.
- [4] F. Liu, Y. Yarom, Q. Ge, G. Heiser, R.B. Lee, Last-level cache side-channel attacks are practical, in: *2015 IEEE Symposium on Security and Privacy*, IEEE, 2015, pp. 605–622.
- [5] Y. Yarom, K. Falkner, FLUSH+ RELOAD: A high resolution, low noise, L3 cache side-channel attack, in: *23rd {USENIX} Security Symposium ({USENIX} Security 14)*, 2014, pp. 719–732.
- [6] J.L. Hennessy, D.A. Patterson, *Computer Architecture: A Quantitative Approach*, Elsevier, 2011.
- [7] K. Cook, Kernel address space layout randomization, in: *Linux Security Summit*, 2013.
- [8] M. Lipp, M. Schwarz, D. Gruss, T. Prescher, W. Haas, S. Mangard, P. Kocher, D. Genkin, Y. Yarom, M. Hamburg, Meltdown, 2018, arXiv preprint arXiv:1801.01207.
- [9] P. Kocher, J. Horn, A. Fogh, D. Genkin, D. Gruss, W. Haas, M. Hamburg, M. Lipp, S. Mangard, T. Prescher, et al., Spectre attacks: Exploiting speculative execution, in: *2019 IEEE Symposium on Security and Privacy, SP, IEEE*, 2019, pp. 1–19.
- [10] D.T. Meyer, W.J. Bolosky, A study of practical deduplication, *ACM Trans. Storage (ToS)* 7 (4) (2012) 1–20.
- [11] V. Kiriansky, I. Lebedev, S. Amarasinghe, S. Devadas, J. Emer, DAWG: A defense against cache timing attacks in speculative execution processors, in: *2018 51st Annual IEEE/ACM International Symposium on Microarchitecture, MICRO, IEEE*, 2018, pp. 974–987.
- [12] Z. He, R.B. Lee, How secure is your cache against side-channel attacks? in: *Proceedings of the 50th Annual IEEE/ACM International Symposium on Microarchitecture*, 2017, pp. 341–353.
- [13] R. Spreitzer, V. Moonsamy, T. Korak, S. Mangard, Systematic classification of side-channel attacks: A case study for mobile devices, *IEEE Commun. Surv. Tutor.* 20 (1) (2017) 465–488.
- [14] Z. Wang, R.B. Lee, New cache designs for thwarting software cache-based side channel attacks, in: *Proceedings of the 34th Annual International Symposium on Computer Architecture*, 2007, pp. 494–505.
- [15] M. Werner, T. Unterluggauer, L. Giner, M. Schwarz, D. Gruss, S. Mangard, Scattercache: Thwarting cache attacks via cache set randomization, in: *28th {USENIX} Security Symposium ({USENIX} Security 19)*, 2019, pp. 675–692.
- [16] M. Yan, J. Choi, D. Skarlatos, A. Morrison, C.W. Fletcher, J. Torrellas, Invisispec: Making speculative execution invisible in the cache hierarchy (corrigendum), in: *Proceedings of the 52nd Annual IEEE/ACM International Symposium on Microarchitecture*, 2019, pp. 1076–1076.
- [17] G. Saileshwar, M.K. Qureshi, Cleanupspec: An “undo” approach to safe speculation, in: *Proceedings of the 52nd Annual IEEE/ACM International Symposium on Microarchitecture*, 2019, pp. 73–86.
- [18] C. Sakalis, S. Kaxiras, A. Ros, A. Jimborean, M. Sjalander, Efficient invisible speculative execution through selective delay and value prediction, in: *2019 ACM/IEEE 46th Annual International Symposium on Computer Architecture, ISCA, IEEE*, 2019, pp. 723–735.
- [19] M. Behnia, P. Sahu, R. Paccagnella, J. Yu, Z.N. Zhao, X. Zou, T. Unterluggauer, J. Torrellas, C. Rozas, A. Morrison, et al., Speculative interference attacks: Breaking invisible speculation schemes, in: *Proceedings of the 26th ACM International Conference on Architectural Support for Programming Languages and Operating Systems*, 2021, pp. 1046–1060.
- [20] S. Ainsworth, GhostMinion: A strictness-ordered cache system for spectre mitigation, in: *MICRO-54: 54th Annual IEEE/ACM International Symposium on Microarchitecture*, 2021, pp. 592–606.
- [21] N.P. Jouppi, Improving direct-mapped cache performance by the addition of a small fully-associative cache and prefetch buffers, *SIGARCH Comput. Archit. News* 18 (2SI) (1990) 364–373, [Online]. Available: <https://doi.org/10.1145/325096.325162>.
- [22] D. Gruss, R. Spreitzer, S. Mangard, Cache template attacks: Automating attacks on inclusive last-level caches, in: *24th {USENIX} Security Symposium ({USENIX} Security 15)*, 2015, pp. 897–912.
- [23] D. Gruss, C. Maurice, K. Wagner, S. Mangard, Flush+ Flush: a fast and stealthy cache attack, in: *International Conference on Detection of Intrusions and Malware, and Vulnerability Assessment*, Springer, 2016, pp. 279–299.
- [24] R. McIlroy, J. Sevcik, T. Tebbi, B.L. Titzer, T. Verwaest, Spectre is here to stay: An analysis of side-channels and speculative execution, 2019, arXiv preprint arXiv:1902.05178.
- [25] Z. He, G. Hu, R. Lee, New models for understanding and reasoning about speculative execution attacks, in: *2021 IEEE International Symposium on High-Performance Computer Architecture, HPCA, IEEE*, 2021, pp. 40–53.
- [26] C. Pierce, M. Spisak, K. Fitch, Capturing Oday exploits with perfectly placed hardware traps, in: *Proc. BlackHat Conf, Vol. 7*, 2016.
- [27] H. Wang, H. Sayadi, S. Rafatirad, A. Sasan, H. Homayoun, Scarf: Detecting side-channel attacks at real-time using low-level hardware features, in: *2020 IEEE 26th International Symposium on on-Line Testing and Robust System Design, IOLTS, IEEE*, 2020, pp. 1–6.
- [28] C. Li, J.-L. Gaudiot, Online detection of spectre attacks using microarchitectural traces from performance counters, in: *2018 30th International Symposium on Computer Architecture and High Performance Computing, SBAC-PAD, IEEE*, 2018, pp. 25–28.
- [29] N. Binkert, B. Beckmann, G. Black, S.K. Reinhardt, A. Saidi, A. Basu, J. Hestness, D.R. Hower, T. Krishna, S. Sardashti, R. Sen, K. Sewell, M. Shoaib, N. Vaish, M.D. Hill, D.A. Wood, The Gem5 simulator, *SIGARCH Comput. Archit. News* 39 (2) (2011) 1–7, [Online]. Available: <https://doi.org/10.1145/2024716.2024718>.
- [30] S. Kim, F. Mahmud, J. Huang, P. Majumder, N. Christou, A. Muzahid, C.-C. Tsai, E.J. Kim, Revive: Reusing victim cache to prevent speculative cache leakage, in: *2020 IEEE Secure Development, SecDev, IEEE*, 2020, pp. 96–107.
- [31] G.B. Bell, M.H. Lipasti, Deconstructing commit, in: *Proceedings of the 2004 IEEE International Symposium on Performance Analysis of Systems and Software, ISPASS '04, IEEE Computer Society, USA*, 2004, pp. 68–77.

- [32] G. Saileshwar, C.W. Fletcher, M. Qureshi, Streamline: A fast, flushless cache covert-channel attack by enabling asynchronous collusion, in: Proceedings of the 26th ACM International Conference on Architectural Support for Programming Languages and Operating Systems, in: ASPLOS 2021, Association for Computing Machinery, New York, NY, USA, 2021, pp. 1077–1090, [Online]. Available: <https://doi.org/10.1145/3445814.3446742>.
- [33] K. So, R. Rechtschaffen, Cache operations by MRU change, *IEEE Trans. Comput.* 37 (6) (1988) 700–709.
- [34] J. Kong, O. Aciicmez, J.-P. Seifert, H. Zhou, Deconstructing new cache designs for thwarting software cache-based side channel attacks, in: Proceedings of the 2nd ACM Workshop on Computer Security Architectures, 2008, pp. 25–34.
- [35] F. Liu, H. Wu, K. Mai, R.B. Lee, Newcache: Secure cache architecture thwarting cache side-channel attacks, *IEEE Micro.* 36 (5) (2016) 8–16.
- [36] F. Mosquera, N. Guler, K. Kavi, G. Mehta, H. Sun, CHASM: Security evaluation of cache mapping schemes, in: International Conference on Embedded Computer Systems, Springer, 2020, pp. 245–261.
- [37] M.K. Qureshi, CEASER: Mitigating conflict-based cache attacks via encrypted-address and remapping, in: 2018 51st Annual IEEE/ACM International Symposium on Microarchitecture, MICRO, IEEE, 2018, pp. 775–787.
- [38] R. Brotzman, D. Zhang, M. Kandemir, G. Tan, Ghost thread: Effective user-space cache side channel protection, in: Proceedings of the Eleventh ACM Conference on Data and Application Security and Privacy, 2021, pp. 233–244.
- [39] N. Abu-Ghazaleh, D. Ponomarev, D. Evtushkin, How the spectre and meltdown hacks really worked, *IEEE Spectr.* 56 (3) (2019) 42–49.
- [40] M. Löw, Overview of meltdown and spectre patches and their impacts, *Adv. Microkernel Oper. Syst.* (2018) 53.
- [41] J. Fustos, M. Bechtel, H. Yun, SpectreRewind: Leaking secrets to past instructions, in: Proceedings of the 4th ACM Workshop on Attacks and Solutions in Hardware Security, 2020, pp. 117–126.
- [42] M.F.A. Kadir, J.K. Wong, F. Ab Wahab, A.F.A.A. Bharun, M.A. Mohamed, A.H. Zakaria, Retpoline technique for mitigating spectre attack, in: 2019 6th International Conference on Electrical and Electronics Engineering, ICEEE, IEEE, 2019, pp. 96–101.
- [43] N. Amit, F. Jacobs, M. Wei, Jumpswitches: restoring the performance of indirect branches in the era of spectre, in: Proceedings of the 2019 USENIX Conference on Usenix Annual Technical Conference, 2019, pp. 285–299.
- [44] P. Li, L. Zhao, R. Hou, L. Zhang, D. Meng, Conditional speculation: An effective approach to safeguard out-of-order execution against spectre attacks, in: 2019 IEEE International Symposium on High Performance Computer Architecture, HPCA, IEEE, 2019, pp. 264–276.
- [45] J. Fustos, F. Farshchi, H. Yun, Spectreguard: An efficient data-centric defense mechanism against spectre attacks, in: Proceedings of the 56th Annual Design Automation Conference 2019, 2019, pp. 1–6.
- [46] R. Ahmad, M.Z. Afzal, S.F. Rashid, M. Liwicki, T. Breuel, A. Dengel, Kpti: Katib's pashto text imagebase and deep learning benchmark, in: 2016 15th International Conference on Frontiers in Handwriting Recognition, ICFHR, IEEE, 2016, pp. 453–458.